

PBM IGENIX® TWO-WAY BALL VALVES

Tank Bottom Series 9 Cast/Forged Series 8 , 1/2" - 6"



DESIGN FEATURES:

- Unique Adjust-O-Seal® feature allows in-line valve adjustment to compensate for normal wear on valve seats. Note: **FI Series Tank Bottom DO NOT have o-rings.**
- Pad radius facilitates efficient drainage and reduces the pocket area above the ball.
- Upstream and downstream bubble-tight sealing capability allows valve body cleaning, purging, and draining.
- Stem assembly accommodates PBM Direct Mount Actuation for accurate alignment and increased cycling life.
- Forged and cast valves are low-controlled ferrite.
- True-Bore® (valve bore same as connecting tubing) – no puddling
- ASME BPE compliant
- Available in Angle Stem versions for applications where automation may interfere with tank head or jacket.
- Valves are rated to full vacuum.
- Certified Material Test Report (CMTRS) provided for wetted components.
- Surface finishes are achieved without the use of ADIs (Animal Derived Ingredients).

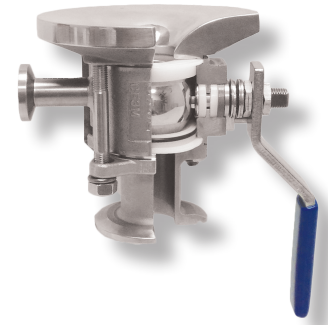

SPECIFICATIONS	Sanitary Tank Bottom Valves
Sizes	1/2" - 6" Series 9, 1/2" - 4" Series 8
Material	316L, low ferrite cast and forged, Hastelloy™, AL6XN™, others
Temperatures	Ambient for V-TEF™ to 400° F, S-TEF® to 450° F
End Connections	Extended tube, hygienic clamp, compression ends (1/2" - 1")
Seats & Seals	White V-TEF™ standard, others available
Stem Packing Material	V-TEF™ and S-TEF®
Body Bolts & Nuts	18-8 Stainless Steel
Maximum Working Pressure	up to 600 psig CWP depending on valve series, size and temperature
Temperatures	up to 450° F depending on seat and seal material
Polish	Standard internal polish of 20 Ra ID Series 8, 30 Ra ID Series 9

CV Values (gpm), FI Series 8/Series 9	
Size	End Connection
	X-
1/2"	8.9
3/4"	34
1"	62
1-1/2"	175
2"	480
2-1/2"	870
3"	1,550
4"	3,750
6"	5,000

ID Surface Finish, Ra Readings for Valves per ASME BPE			
Surface Finish	PBM Polish Code	μ-in.	μ-m.
Mechanical Polish			
SF 1	A	20 Ra max	0.51
SF 2	A	25 Ra max	0.64
SF 3	-	30 Ra max	0.76
Mechanical Polish and Electropolish			
SF 4	G	15 Ra max	0.38
SF 5	F	20 Ra max	0.51
SF 6	F	25 Ra max	0.64

How To Order:

PRODUCT (1-2) MATERIAL (3-4)		SIZE (5) SERIES (6)		END CONN. (7-8)		SEAT & SEAL (9)		WELD PAD (10-11)		BALL & STEM (12)		OPERATOR (13-14)		POLISH (15-16)		
FI	HL Cast (Ser. 9) 316L S / S	C	1/2"	8	F - Ext. Butt-weld for Tube	G	V-TEF™ Seats / Seals	--	Standard Weld Pad	-	Standard Ball and Stem	--	W/ Standard Lever Handle	-	30 Ra ID (Std. Series 9)	
	HF Forged 316L S / S	D	3/4"	9	X - Hygienic Clamp	J	V-TEF™ Seats / Seals VTFE Cavity Fillers	02	w/o weld pad w/ shipping pad	F	Internal / External Grounding	02	W/O Handle W/ Stem Actuator Prep	A	20 Ra ID (Std. Series 8)	
	Other material options available - Contact PBM.	E	1"		G - Female Cherry Burrell	H	S-TEF® Seats / Seals		Other Weld Pad Options available - Contact PBM.	G	17-4PH Stem	04	Locking Lever Handle	D	15 Ra ID	
		G	1-1/2"		H - Male Cherry Burrell			08		Gear Operator (Req'd for 6")	E	10 Ra ID				
		H	2"			I	S-TEF® Seats / Seals VTFE Cavity Fillers				18	Extended Handle (2-1/2" thru 4")	F	Extended Handle (1/2" thru 2")	F	20 Ra ID after Electro Polish
		K	3"			K	UHMWPE Seats / Seals				20	DA 80psig actuator	G		G	15 Ra ID after Electro Polish
		L	4"			L	UHMWPE Seats / Seals VTFE Cavity Fillers				27	DA 60psig actuator	H		H	10 Ra ID after Electro Polish
		M*	6"		* Not available in forged.					34	SR 80psig actuator					
										41	SR 60psig actuator					

<http://pbmvalve.com/build-a-part-number>

Other seat/seal options available -
Contact PBM.

Other operator options available -
Contact PBM.

More polish available -
Contact PBM.

PBM Igenix® Flush Tank Steam Valves, Manual

Flush Tank Valve with Locking Handle

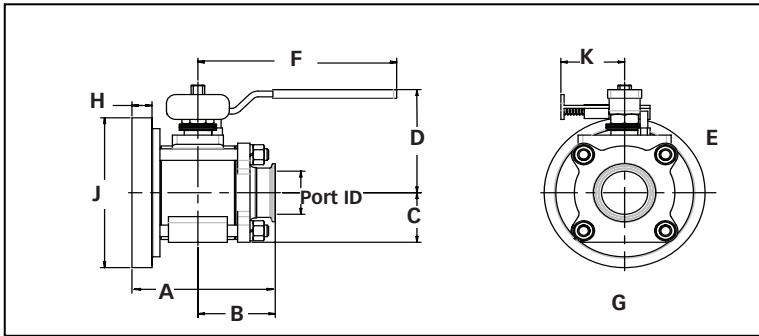

Flush Tank Valve with Gear Operator (6" only)

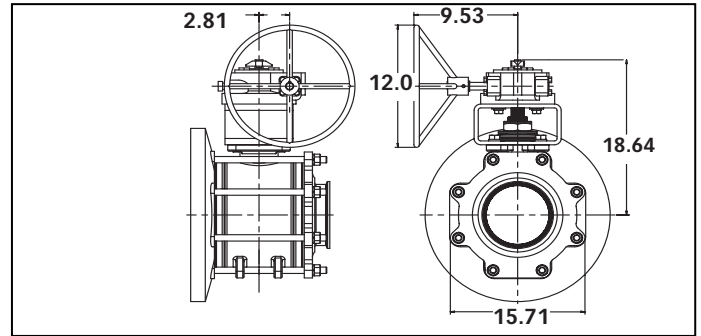

Flush Tank Sanitary Dimensioned valves in inches													Locking Handle	
Valve Size	Size Code	I.D. Port	A	B	C	D	E	F	G	H	J	Approx. Wgt (lbs)	K	Hole Dia. for Lock
1/2"	C	0.37	2.83	1.75	1.70	0.75	2.05	4.00	1.50	0.30	2.75	1.6	1.55	.28
3/4"	D	0.62	3.16	2.00	1.86	0.85	2.23	4.00	1.68	0.30	3.00	2	1.55	.28
1"	E	0.87	3.70	2.25	2.38	1.09	3.01	4.15	2.18	0.68	3.75	3.6	1.62	.25
1-1/2"	G	1.37	4.98	2.75	3.89	1.68	5.07	8.81	3.31	0.31	5.50	12	2.57	.38
2"	H	1.87	5.79	3.12	4.67	2.15	4.51	8.03	4.30	0.49	6.50	22	2.57	.38
3"	K	2.87	7.52	4.00	6.76	2.77	6.76	12.06	5.54	0.85	9.00	33	3.47	.38
4"	L	3.84	9.59	5.00	7.53	3.66	7.53	12.06	7.33	1.18	11.50	94	3.47	.38
6"*	M	5.78	12.78	6.50	12.14	6.18	NA	NA	12.36	1.34	17.00	164	NA	NA

*Cast Series 9 Only

ACTUATED DIMENSIONS

Unit of Measure = inches
Dimensions based on actuators used with V-TEF™ seats.

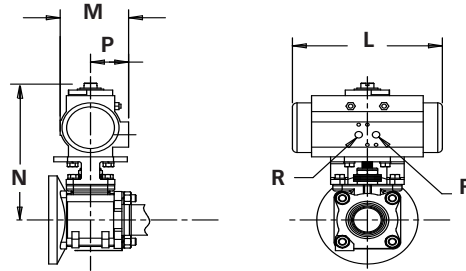

Size	80 PSI Spring Return					60 PSI Spring Return					60, 80 PSI Double Acting				
	L	M	N	P	R	L	M	N	P	R	L	M	N	P	R
1/2"	5.55	2.80	5.45	1.61	1/8 NPT	5.55	3.17	5.90	1.77	1/8 NPT	5.55	2.80	5.45	1.61	1/8 NPT
3/4"	5.55	2.80	5.59	1.61	1/8 NPT	6.46	3.17	6.04	1.77	1/8 NPT	5.55	2.80	5.59	1.61	1/8 NPT
1"	6.46	3.17	6.51	1.77	1/8 NPT	8.27	3.72	7.22	2.07	1/8 NPT	5.55	2.80	6.06	1.61	1/8 NPT
1-1/2"	9.47	4.17	9.65	2.30	1/8 NPT	10.83	4.84	9.65	2.68	1/4 NPT	8.27	3.72	9.10	2.07	1/8 NPT
2"	10.83	4.84	10.45	2.68	1/4 NPT	13.11	5.39	11.80	2.87	1/4 NPT	8.27	3.72	9.39	2.07	1/8 NPT
2-1/2"	13.11	5.39	13.48	2.87	1/4 NPT	14.65	5.83	13.96	3.15	1/4 NPT	13.11	5.39	13.48	2.87	1/4 NPT
3"	14.65	5.83	14.21	3.15	1/4 NPT	17.13	6.46	15.10	3.44	1/4 NPT	13.11	5.39	13.73	2.87	1/4 NPT
4"	17.13	6.46	15.86	3.44	1/4 NPT	19.69	7.32	16.80	3.90	1/4 NPT	13.11	5.39	14.51	2.87	1/4 NPT
6"	22.78	8.54	23.02	4.29	1/4 NPT	22.64	11.42	27.78	5.71	1/4 NPT	22.78	8.54	23.02	4.29	1/4 NPT



<http://www.pbmvalve.com/valves/tank-bottom-valve>

<http://pbmvalve.com/maintenance-instructions>

www.PBMValve.com

PBM, Inc. • 1070 Sandy Hill Road, Irwin, PA 15642

Phone: 800.967.4PBM • 724.863.0550

E-mail: info@pbmvalve.com

